

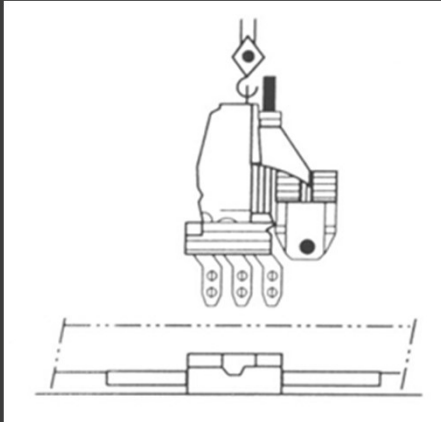

**SPI PILING**  
A E YATES GROUP

## Procedure for press-in work with reaction stand



### A: Reaction stand setting

Set the reaction stand level horizontally.  
Next, set the Silent Piler and the weights with a crane.

### B: Beginning Press-In of the Steel Sheet Pile

Erect a steel sheet pile to the vertical in the Silent Piler and check it for perpendicularity then begin pressing it in.

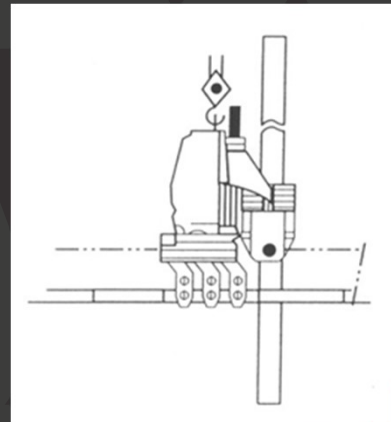

**STEEL PILING CONTRACTOR OF CHOICE**



**SPI McGRATTAN**  
A E YATES GROUP



# SPI PILING

A E YATES GROUP

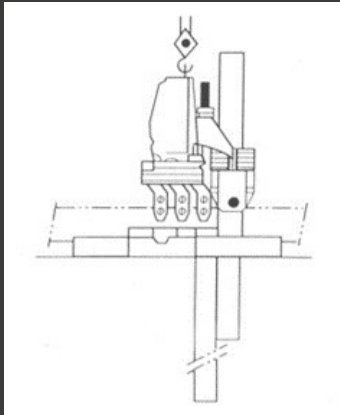

## C: Start Self-Movement of the Silent Piler

Press in the first pile up to the specified depth.  
Next, press in the second pile halfway in, and grasp it with the chuck.  
Then raise the main body of the Silent Piler.

## D: Self-Movement of the Silent Piler

On completion of raising the main body of the Silent Piler, move it forward.  
Reverse the left/right position of the clamp.

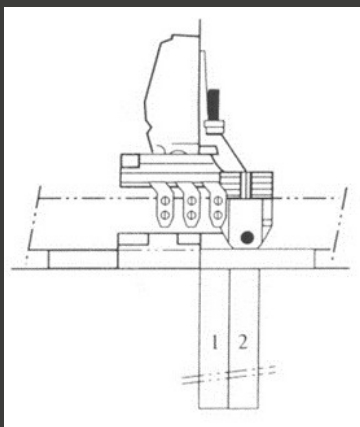
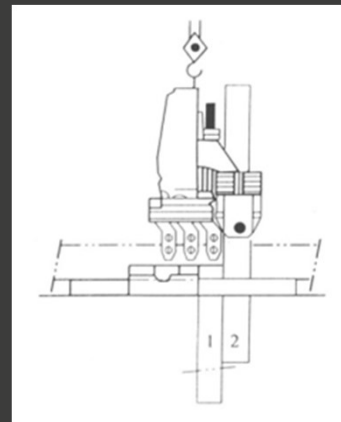

## E: Complete of Self-Movement

Lower the main body of the Silent Piler.  
Clamp the reaction Stand and the first steel sheet pile and press in the second pile up to the specified depth in the ground.

**STEEL PILING CONTRACTOR OF CHOICE**



**SPI PILING**  
A E YATES GROUP

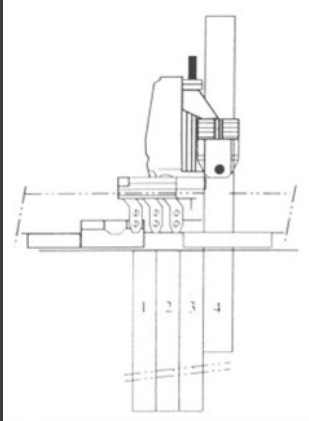

F:

Press in the third pile up to the specified depth and press the fourth pile halfway in.

#### G: Removal of the Reaction Stand

When the Silent Piler finishes self-moving at the fourth pile and grabs three clamps, remove the reaction stand. Then press 'in' the piles again sequentially repeating the self-movement of the Silent Piler.

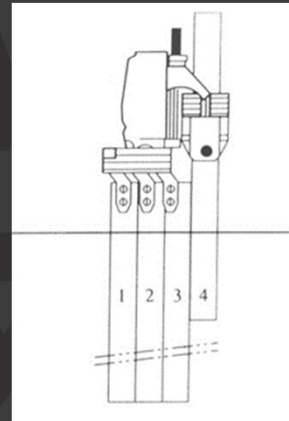

**STEEL PILING CONTRACTOR OF CHOICE**



**SPI McGRATTAN**  
A E YATES GROUP

# GPF 150 Reaction Stand Details)

NOT TO SCALE

A

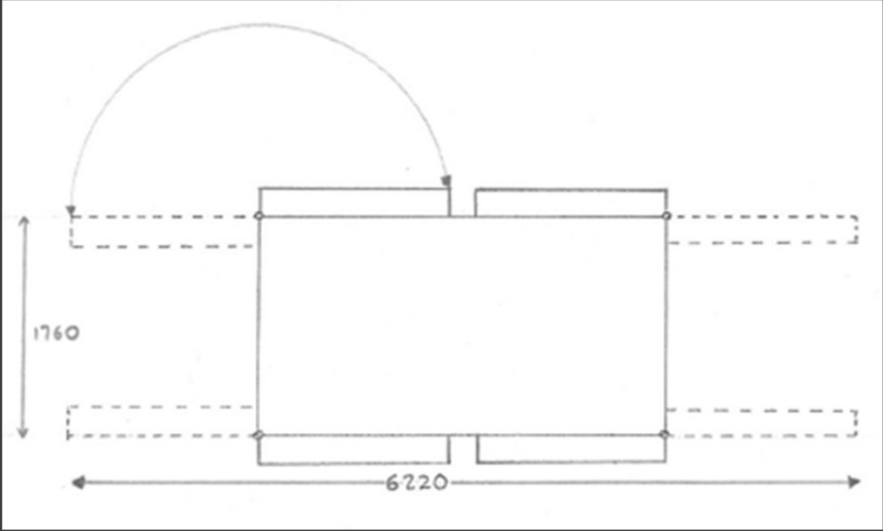

**SPI PILING**  
A E YATES GROUP

B

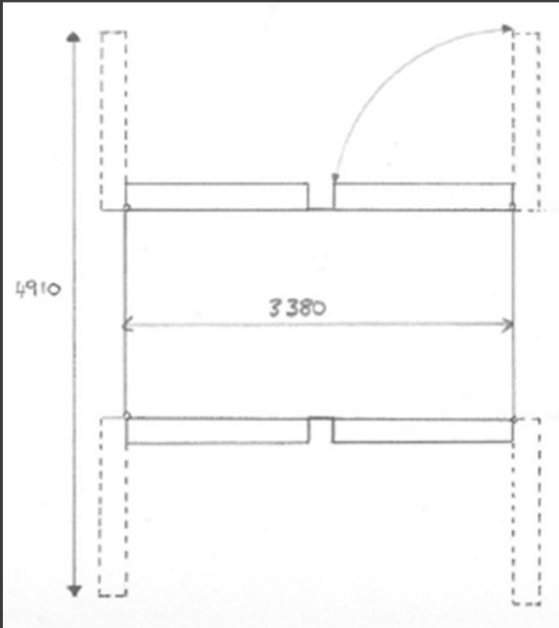

**SPI McGRATTAN**  
A E YATES GROUP



## Clamp Configuration

The still worker can install sheet piles of 400mm, 500mm and 600mm. the leg clamps are used in different configurations to install the different sheet pile sections.

In case of 400mm-pitch, normally 2 clamps are used. The drawing below shows the use of an optional extra No.1 clamp when enough reaction force cannot be obtained.

600 mm

500mm

400mm

